

## DURAGAL® LINTELS

All DuraGal® products provide a superior level of corrosion resistance through the unique chemical composition of the zinc coating, which also contains 3% Magnesium and 2.5% Aluminium. This advanced galvanised coating allows consistent and uniform quality during manufacture, can be produced in high volume at any length and provides an attractive, spangle-free surface finish that removes the need for secondary galvanising operations.

DuraGal® Lintels are readily available in an extensive range of sizes and thicknesses, as shown below:

Designation			Pack Size	Mass (kg/m)
D (mm)	B (mm)	T (mm)		
<b>12.0 metres</b>				
90	90	5	18	6.754
		6	18	8.112
100	100	6	16	9.078
100	75	6	16	7.871
125	75	6	16	9.078
150	100	6	16	11.492

## DuraGal® Profiles

THE DIFFERENCE IS DURAGAL

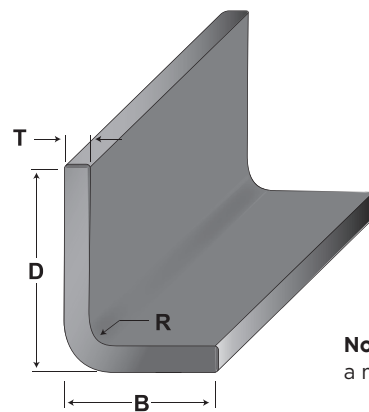
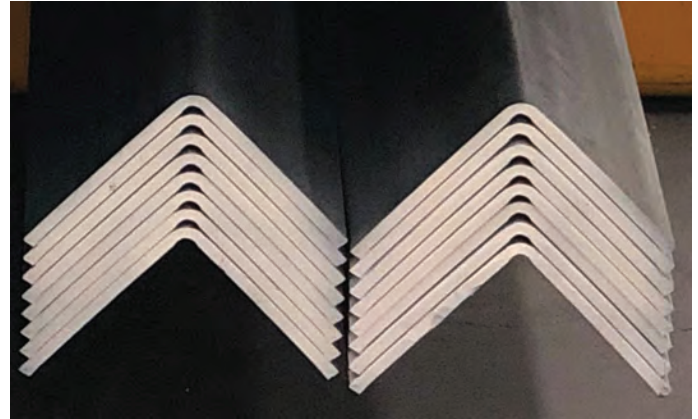

**Note:** Radius R is a minimum 3.5mm

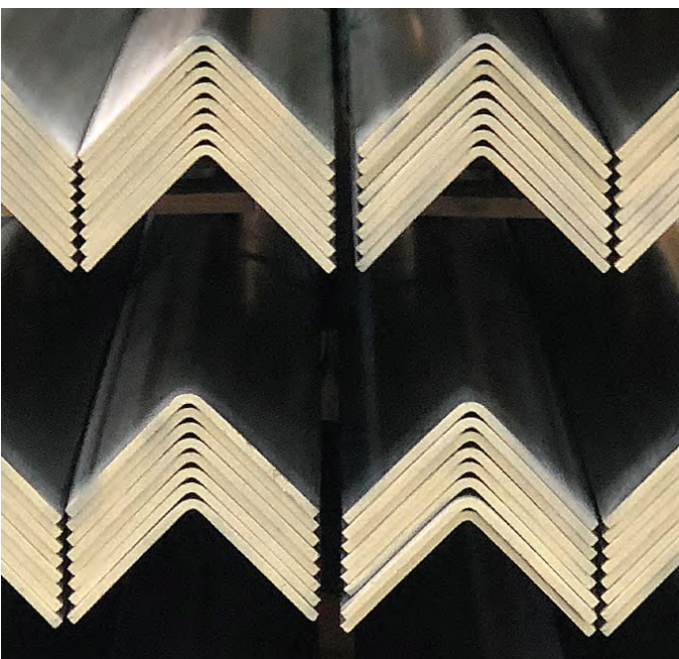

### NEED SOMETHING DIFFERENT?

Australian Rollforming is a custom metal rollforming specialist with the capability to rollform an almost infinite variety of profiles using a wide range of metals.

DuraGal® Lintels can be manufactured to your desired dimensions and lengths with in-line hole punching or edge bevelling also available (non-standard items may be subject to minimum order quantities). Additional technical specifications, including section properties, are available on request.



Contact us to discuss your requirements.